

DATASHEET

ORIGINALNAi LED-160-NAI

- Maintenance-free LED technology
- Standard NAI bus interface for power supply and communication
- Suitable for series connection of multiple NAI components

This marine lantern is intended for use on offshore wind turbines. It satisfies the requirements of the IALA recommendation O-139*.

The device is distinguished by low power consumption, a long service life and robust construction. Equipped with light emitting diodes (LEDs) as light sources the optical systems is designed for long maintenance intervals. Utilising LED technology provides the greatest possible light output.

The lantern's integrated NAI bus interface is used to supply power, to control the flashcode and intensity, and to transmit status and error messages to the central NAI controller, so that they are available to the central SCADA system.

Using the integrated daylight sensor, an autonomous fallback solution is possible so that in the case of interrupted bus communication, the light is switched on when the environmental brightness falls below a minimum brightness level (configurable).

* IALA Recommendations O-139, "The marking of man-made offshore structures"

The day-night switching occurs depending

- on the ambient brightness and
- the current date in conjunction with the Cuxhaven calendar (North Sea or Baltic Sea) or
- the geographic position of the device according to the astronomical clock.

The exact flashcode synchronisation of the connected navigation light components is guaranteed even in the event of a weak or absent GPS/GLONASS signal over a time period of at least 2 hours.

Dimensions & Weight

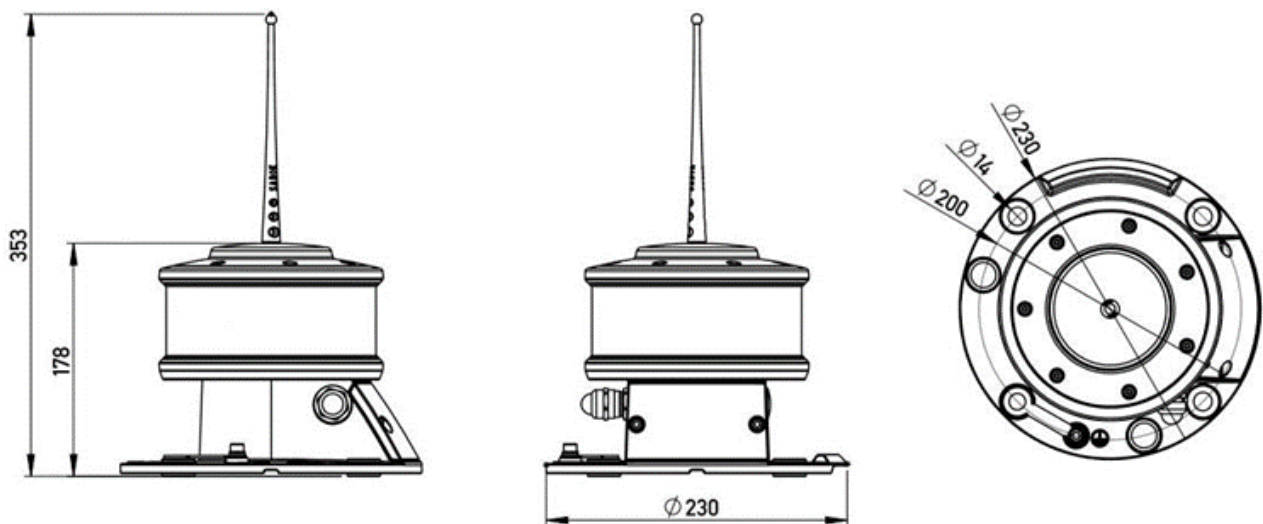

Diameter optics	160 mm
Optical head diameter	171 mm
Diameter of optical head with segment panel	183 mm
Diameter mounting foot	230 mm
Height without bird spike	178 mm
Height with bird spike	253 mm
Weight incl. mounting foot	2.55 kg

Material

Housing (Device foot, head, cover for socket)	Anodised, powder-coated aluminium (AlSi12)
Lens	PMMA
Lens cover	PC (MAKROLON®)
Cable gland	Nickel-plated brass
Earthing connection	Stainless steel 1.4571
Cover indicator LED	PMMA
Insulation sleeve	PA
Seals	TPE, injection-molded
Pressure compensation valve for socket and housing	PTFE membrane

Optical System

LED 160 NAI optical system for use on anchored offshore plants	
Light colour 2-nautical mile lantern, 5-nautical mile lantern 3-nautical mile lantern 10-nautical mile lantern	Yellow, according to IALA recommendation E-200-1 Red, according to IALA recommendation E-200-1 White, according to IALA recommendation E-200-1
Maximum light intensity LED-160-NAI, LED-160-NAI, LED-160-NAI-S, LED-160-NAI-GPS, LED-160-NAI-GPS-S LED-160-NAI-GPS-R LED-160-NAI-2NM, LED-160-NAI-2NM-GPS LED-160-NAI-H, LED-160-NAI-H-S	Approx. 140 cd Approx. 30 cd Approx. 10 cd Approx. 3000 cd
Beam angle (vertical) LED-160-NAI, LED-160-NAI, LED-160-NAI-S LED-160-NAI-GPS, LED-160-NAI-GPS-S LED-160-NAI-GPS-R, LED-160-NAI-2NM LED-160-NAI-2NM-GPS, LED-160-NAI-2NM-GPS-S LED-160-NAI-H, LED-160-NAI-H-S	8° (FWHM) (= full width at half maximum) 5° (FWHM) (= full width at half maximum)

LED 160 NAI optical system for use on floating offshore plants	
Light colour	Yellow, according to IALA recommendation E-200-1
Light intensity at +/- 6° from horizontal plan	> 75 cd
Peak intensity	< 400 cd
Beam angle (vertical)	> 10° (FWHM) (= full width at half maximum)

Components



1. Device head with optics and bird spike (or dummy plug)
2. Housing cover for socket with spring terminal block
3. Indicator LED, light sensor
4. Second cable gland M20 or blanking plug
5. Device foot with integrated socket and third cable gland M20 or blanking plug on the bottom side
6. Cable gland M20
7. Earthing connection



Note: All housing components including the cable glands satisfy the IP67 degree of protection requirements according to IEC 60529. During connection and assembly, ensure that no moisture or dirt penetrates into the open socket.

	Size	For cable diameter	Key width
EMC Cable Gland	M20 x 1.5	7.5 – 14.0 mm	24 mm

Electrical Connection

Electrical connection of spring terminal block	2.5 mm ²
Rated voltage	DC 24.0 V (-20 % ... +25 %)
Nominal voltage	DC 24 V
Power consumption, maximum, at max. intensity 2/3/5-nautical mile lantern LED-160-NAI, LED-160-NAI-S LED-160-NAI-GPS, LED-160-NAI-GPS-S LED-160-NAI-R LED-160-NAI-2NM LED-160-NAI-2NM-GPS	2 W
Power consumption, maximum, at max. intensity 5-nautical mile lantern, wide optics LED-160-NAI-GPS-W	6 W
Power consumption, maximum, at max. intensity 10-nautical mile lantern LED-160-NAI-H, LED-160-NAI-H-S 30 W	30 W
EMC cable gland (M20x1.5)	Cable diameter of 7.5 – 14 mm

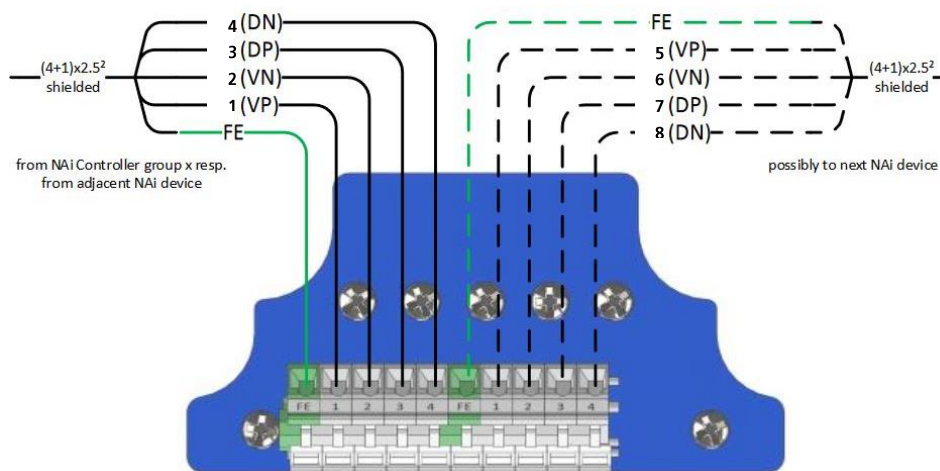

1	VPI	Power supply input (Positive)
2	VN	Power supply input (Negative)
3	DP	NAi data (Positive)
4	DN	NAi data (Negative)
5	VPO	Power supply output (Positive – to next device)
6	VN'	Power supply output (Negative – to next device)
7	DP'	NAi data (Positive – to next device)
8	DN'	NAi data (Negative – to next device)

Environmental Conditions

Regulations	IEC 60945, device type 'exposed'
Ambient temperature (operation)	-25 °C to 55 °C
Ambient temperature (storage / transport)	-40 °C to 70 °C
Humidity (operation / storage / transport)	Max. 95 % acc. To IEC 60945
Atmospheric pressure (operation / storage / transport)	80 kPa to 108 kPa
Degree of protection (acc. to IEC 60529)	IP67

Electrical Safety and Health

Protection class	Class III
Overvoltage protection	Class III
Pollution degree	3

Reliability

MTBF according to Siemens standard SN 29500-1 (ambient temperature of 50 °C) 2 and 5-nautical mile lantern without GPS 2 and 5-nautical mile lantern with GPS 10-nautical mile lantern	1 230 000 h 760 000 h 560 000 h
Minimum service life of LEDs	100 000 h

Mechanical Requirements

Vibration testing sinusoidal vibrations	acc. to IEC 60945
---	-------------------

Compliance

Electromagnetic Compatibility	EN 60945:2002, category "exposed" EN 61000-6-2:2005
Environmental	EN 60945:2002, category "exposed" IEC 61892-1:2019 EN 60598-1:2015 + A1:2008
Product safety	EN 60598-1:2015 + A1:2008 EN 62471:2008 **
Mechanical	EN 60945:2002, category "exposed" EN 60598-1:2015 + A1:2008 EN 61892-3:2019

** Relevant for the 10 NM lanterns LED-160-NAI-H and LED-160-NAI-H-S only.

Ordering Information

Item Number	Product ID	Details
3040150X	LED-160-NAI	5-nautical mile lantern with NAI bus interface
3040160X	LED-160-NAI-S	5-nautical mile lantern with NAI bus interface, with segment panel
3040120X	LED-160-NAI-GPS	5-nautical mile lantern with NAI bus interface, with integrated GPS module
30401400 30401401	LED-160-NAI-GPS-S	5-nautical mile lantern with NAI bus interface, with integrated GPS module, with segment panel
30401700	LED-160-NAI-R	3-nautical mile lantern with NAI bus interface, red
30401800	LED-160-NAI-2NM	2-nautical mile lantern with NAI bus interface
30401900	LED-160-NAI-2NM-GPS	2-nautical mile lantern with NAI bus interface, with integrated GPS module
30401000	LED-160-NAI-H	10-nautical mile lantern with NAI bus interface, with integrated GPS module
30401300	LED-160-NAI-H-S	10-nautical mile lantern with NAI bus interface, with integrated GPS module, with segment panel
30402200	LED-160-NAI-GPS-W	5-nautical mile lantern with NAI bus interface, vertically wide optics for use on floating wind turbines