



## Data sheet

# LED 160HS NAI 10 nautical mile

- **For use as a 10 nautical mile beacon on offshore wind turbines**
- **Type approval – WSV FVT Koblenz**
- **Maintenance-free LED technology**
- **Standard NAI bus interface for power supply and communication**
- **Suitable for series connection of multiple NAI components**

This nautical lantern is intended for use as a 10 nautical mile lantern on offshore wind turbines. It satisfies the requirements of the IALA recommendation O-139<sup>1</sup> and the guideline 'offshore structures'<sup>2</sup> of the WSV<sup>3</sup> according to the 'Technical Requirements' TF02 '10 nautical mile beacon (white)'.

The device is distinguished by low power consumption, a long service life and robust construction.

Equipped with light emitting diodes (LEDs) as light sources the optical systems is designed for long maintenance intervals. Utilising LED technology provides the greatest possible light output.

The lantern's integrated NAI bus interface is used to supply power, to control the flashcode and intensity, and to transmit status and error messages to the central NAI controller, so that they are available to the central SCADA system.

Using the integrated daylight sensor, an autonomous fallback solution is possible so that in the case of interrupted bus communication, the light is switched on when the environmental brightness falls below a minimum brightness level (configurable).

The nautical lantern comes with a sector blind for the standard beam angle of 94°. It can easily be adjusted for wider beam angles.

---

<sup>1</sup> IALA Recommendations O-139, "The marking of man-made offshore structures"

<sup>2</sup> Guideline 'Offshore Structures' [German version: Richtlinie „Offshore-Anlagen“ zur Gewährleistung der Sicherheit und Leichtigkeit des Schiffsverkehrs Version 2.0]

<sup>3</sup> Federal German Waterways and Shipping Administration

## Technical Data

### Dimensions, weight

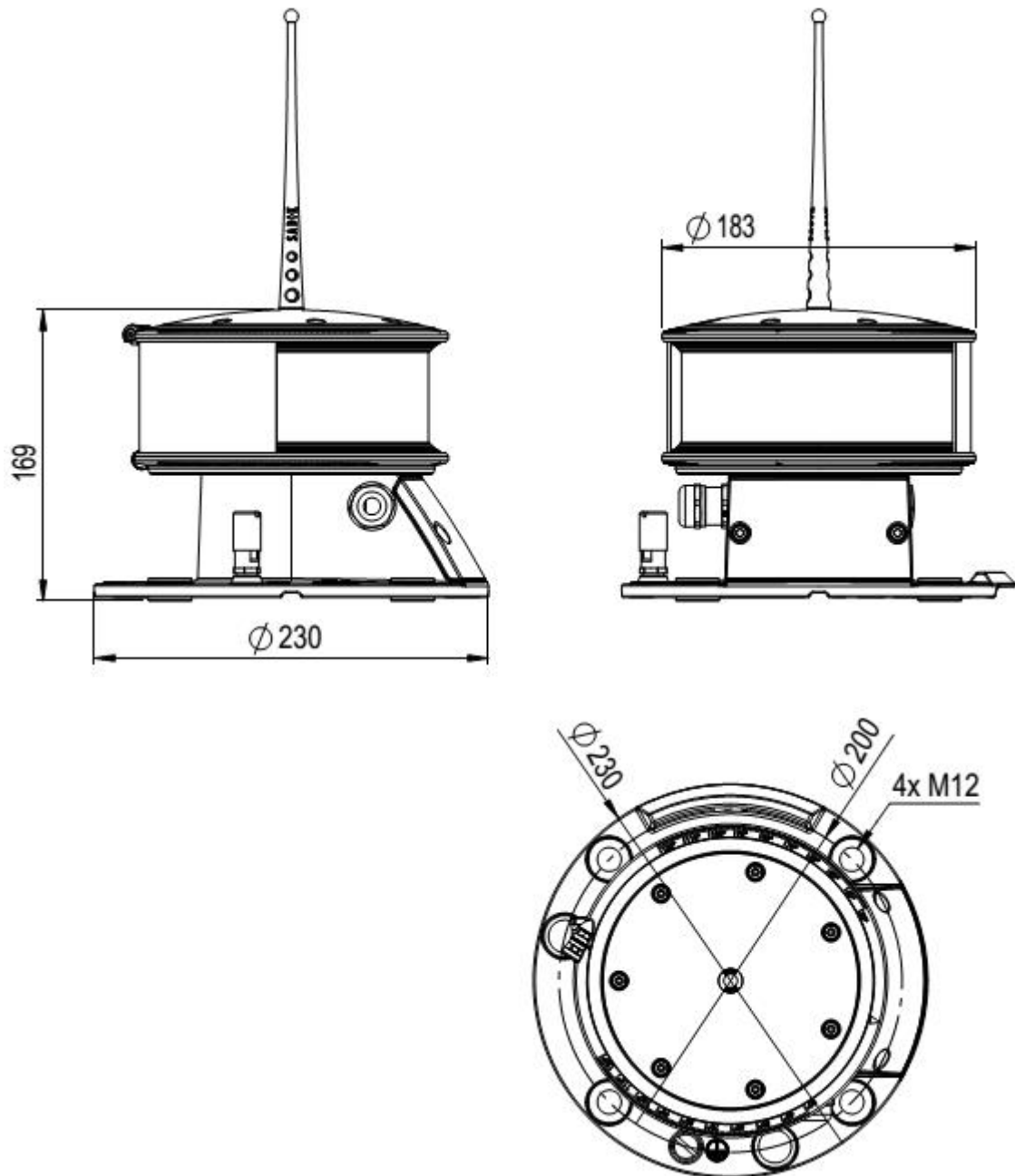

Diameter optics (with	170 mm
Diameter mounting foot	230 mm
Height without bird spikes	178 mm
Weight incl. mounting foot:	2.50 kg

## Electrical connection

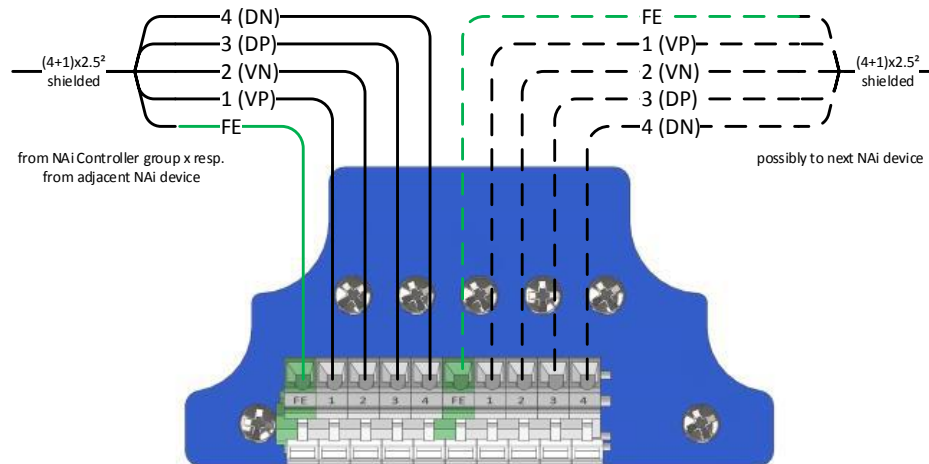

<b>Electrical connection</b>	Spring terminal block, max. 2.5 mm <sup>2</sup>
<b>Operating voltage <math>V_{IN}</math></b>	9 to 36 V DC
<b>Power consumption (<math>V_{IN} = 24</math> V DC - max. intensity)</b>	max. 28 W

## Optical system

<b>Light colour</b>	White
<b>Maximum light intensity (along the optical axis)</b>	approx. 3000 cd
<b>Beam angle (vertical)</b>	5° (FWHM) <sup>4</sup>

## Environmental conditions

<b>Regulations</b>	IEC 60945, device type 'exposed'
<b>Ambient temperature (operation)</b>	-40 to 55 °C
<b>Ambient temperature (storage / transport)</b>	-40 to 70 °C
<b>Humidity (operation / storage / transport)</b>	max. 95 % acc. to IEC 60945
<b>Atmospheric pressure (operation / storage / transport)</b>	80 kPa to 108 kPa
<b>Degree of protection (acc. to IEC 60529)</b>	IP67
<b>Protection class</b>	Class III

## Mechanical requirements

<b>Vibration testing sinusoidal vibrations</b>	acc. to IEC 60945
--	-------------------

## Reliability

<b>MTBF Electronics</b>	2 130 000 h
<b>Minimum LED Lifetime</b>	60 000 h

<sup>4</sup> Specification of the half-value angle: Full width at half maximum (FWHM)

## EMC compliance

EMC requirements		Applied standard	Test standard / Test criteria
EMC emission	Radiated interference emission	EN 60945:2002	IEC/CISPR 16-2-3:2010 Measuring distance 3 m
EMC immunity	Electrostatic discharge (ESD)	EN 60945:2002	IEC 61000-4-2:2008 Criterion B 8 kV air discharge 6 kV contact discharge
	Electromagnetic fields	EN 60945:2002	IEC 61000-4-3:2010 Criterion A Field strength 10 V/m
	Fast transients (burst)	EN 60945:2002	IEC 61000-4-4:2012 Criterion B All connections: Test voltage 1 kV
	High energy transients (surge)	EN 61000-6-2:2005	IEC 61000-4-5:2005 1 kV on NAI bus line (shield)
	Conducted interference	EN 60945:2002	IEC 61000-4-6:2008 Criterion A All connections: Test voltage 10 kV

## Components



1. Device head with optics and bird spike
2. Sector blind
3. Indicator LED, light sensor
4. Second cable gland M20 or blanking plug
5. Housing cover for socket with spring terminal block
6. Cable gland M20
7. Earthing connection
8. Device foot with integrated socket and third cable gland M20 or blanking plug on the bottom side

**Note:** All housing components including the cable glands satisfy the IP67 degree of protection requirements according to IEC 60529. During connection and assembly, ensure that no moisture or dirt penetrates into the open socket.

EMC cable gland <sup>1)</sup>	Size	for cable diameter	Key width
	M20 x 1.5	7.5-14.0 mm	24 mm

<sup>1)</sup> Typ: HELUTOP® MS-EP4

## Material

<b>Housing (Device foot, head, cover for socket)</b>	Anodised, powder-coated aluminium (AlSi12)
<b>Lens</b>	PMMA
<b>Lens Cover</b>	PMMA
<b>Cable gland</b>	Nickel-plated brass
<b>Earthing connection</b>	Nickel-plated brass
<b>Cover indicator LED</b>	PMMA
<b>Insulation sleeve</b>	PA
<b>Seals</b>	TPE, injection-molded
<b>Pressure compensation valve for socket and housing</b>	PTFE membrane